



GEMINI/TITAN

Semi-Scale Model
of GT-3

Your Gemini-Titan II semi-scale model rocket kit consists of the following parts as illustrated in the drawing at right:

- (A) 1 body tube--Part #BT-70
- (B) 1 stuffer tube--Part #BT-20B
- (C) 1 parachute tube--Part #BT-60K
- (D) 2 engine holder tubes--Part #BT-20G
- (E) 3 ring sets--Part #RA-2050
- (F) 2 launching lugs--Part #LL-2D
- (G) 2 engine blocks--Part #EB-20A
- (H) 1 dowel--Part #WD-2
- (I) 1 ring set--Part #TA-21
- (J) 2 stage couplers--Part #JT-50B
- (K) 1 stage coupler--Part #JT-70A
- (L) 1 sheet plastic fin material--Part #CFS-20
- (M) 2 sheets plastic fin material--Part #CFS-40
- (N) 1 Gemini capsule--Part #BNC-60AB
- (O) 1 shroud and pattern sheet--Part #SP-21
- (P) 1 shock cord--Part #SC-2
- (Q) 1 screw eye--Part #SE-1
- (R) 1 parachute--Part #PK-24A
- (S) 1 sheet balsa stock--Part #BFS-40S
- (T) 7 tape strips--Part #TD-2G
- (U) 144" shroud line cord--Part #SLT-1D
- (V) 1 paint pattern sheet--Part #SP-21B
- (W) 2 self-adhesive strips--Part #TH-1
- (X) 1 reject engine casing--Part #EC-2

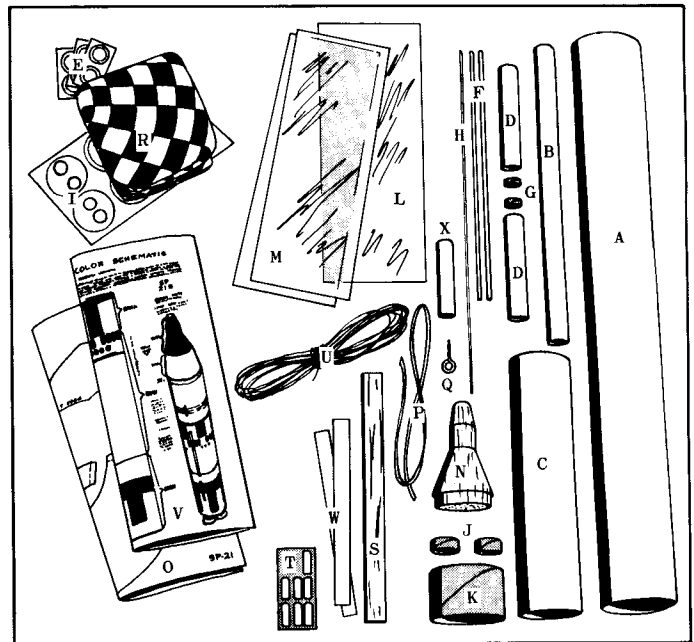

In addition to the materials included with your kit you will also need the following tools and supplies:

- 1) Modeling knife or single edge razor blade
- 2) Scissors
- 3) Extra strong white glue
- 4) Ball point pen or pencil

- 5) Fine and extra fine grit sandpaper
- 6) Clear butyrate dope
- 7) Black, white and silver paint or dope

Read the entire assembly instructions carefully before beginning work on your rocket. Then start construction, following each step in order, checking off each step as it is completed.

- (1) Draw a straight line on each of the engine mounting discs as shown with the line just touching one edge of each engine tube hole. Draw a line on the outside of the JT-70A coupler, parallel to its centerline as shown. Draw a line at right angle to the first line, centered between the two engine tube holes. Do this only on the one disc with the holes which are farthest apart.

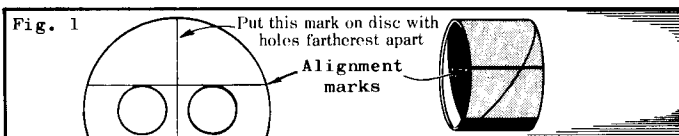

- (2) Apply a line of glue to one edge of the JT-70A coupler. Line up one of the engine mounting discs so the line drawn on it matches the line drawn on the coupler and press the disc in place. Apply glue to the other edge of the coupler and mount the other disc, making sure that the right end of the line on the disc is matched with the line on the coupler (so the inner holes are in line with each other as shown).

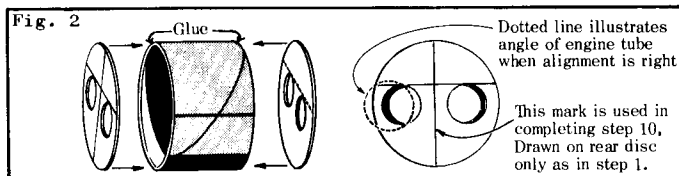

- (3) Glue a 2060 ring to one end of the BT-20B stuffer tube and a 2070 ring to the other end. To do this, slide the rings into position 1/8" from each end of the tube and apply glue fillets to the joints as shown. (The stuffer assembly reduces the volume of space that the ejection charge has to fill, thus giving more positive parachute ejection.)

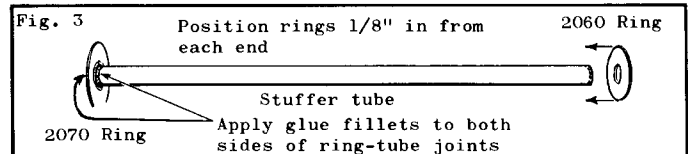

- (4) Glue the two 6070 rings to the BT-60K tube. One ring should be 1/8" from one end, the other 1-3/4" from the other end.

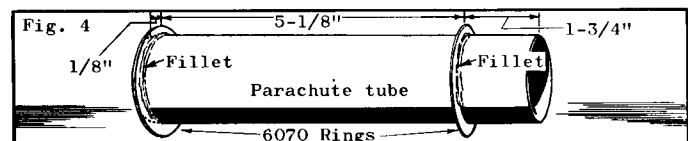

- (5) Glue one 2050 ring to each end of the two JT-50B couplers. This is done by applying glue to the end of the coupler and pressing the ring into place. Set the units aside to dry.

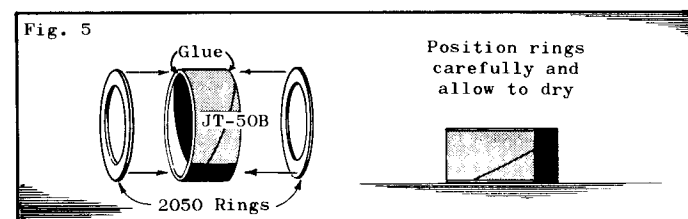

- (6) Mark the reject engine casing 1/4" from one end. Smear glue around the inside of one of the BT-20G engine holder tubes to cover the area shown in fig. 6. Place an engine block in the

end of the tube and push it forward with the casing until the mark on the casing is even with the end of the tube. Do not pause during this operation or the glue may set with the block in the wrong position. Remove the casing immediately. Repeat this operation with the remaining tube and engine block.

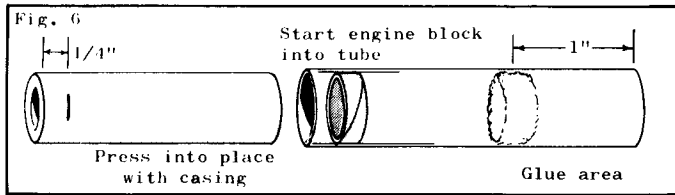

(7) Mark the engine holder tubes 1/8" and 2-5/8" from the end nearest the engine block. Slide one engine holder tube into the holes in the engine mounting discs as shown so the 1/8" mark is even with the surface of the forward disc (the disc with the holes closest together). The tube should be turned so the mark faces the center of the unit. Apply a glue fillet to the two tube-disc joints. Slide the other tube into place, positioning it in the same way, and glue it in place. Set the unit aside to dry.

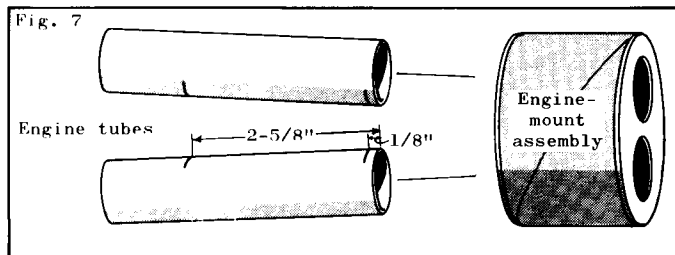

(8) Cut out and form the three shrouds so the markings on them are to the inside. Glue the overlapping ends of the shrouds as shown, making sure that the overlap area is aligned perfectly. Set these pieces aside.

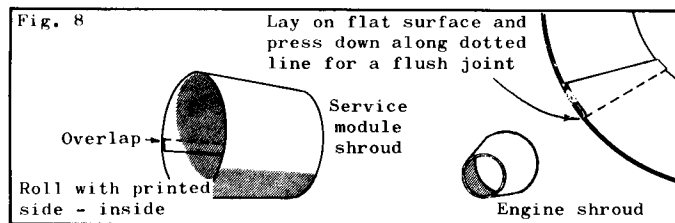

(9) Slide one of the ring-coupler units made in step (5) onto one of the engine holder tubes so the rear ring is even with the mark on the tube. Apply a glue fillet to both ring-tube joints to hold the unit in place on the tube. Slide the other ring-coupler unit onto the other engine holder tube, positioning it so it is even with the first assembly and glue it in place.

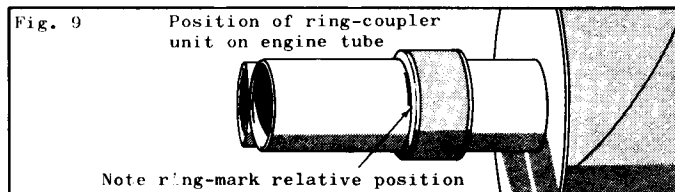

(10) Cut four 3/4" long pieces from the 1/16" diameter dowel. Glue two to each side of the engine mount assembly as shown in fig. 10.

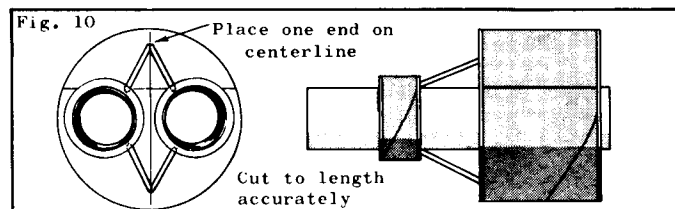

(11) Cut two 1-7/16" long pieces from one of the launching lugs. Wrap one of the self-adhesive strips (part W) around one end of each piece of lug as shown. Glue these pieces to the tail assembly as illustrated in fig. 11B

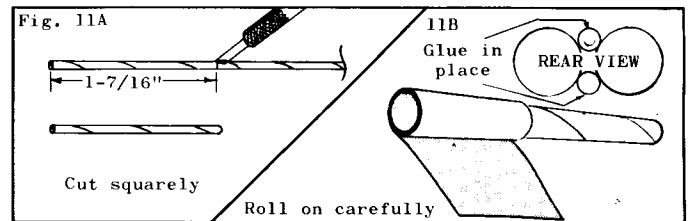

(12) Slide the dummy nozzle cones onto the engine holder tubes. Place one 2050 spacer ring on the end of each holder tube. Position the rings so they are perfectly even with the ends of the tubes and apply glue to the joints. Let the units set for several minutes, then apply glue to the outside edges of the rings and slide the cones rearward until they are seated firmly against the rings. Apply glue to the forward cone-tube joints.

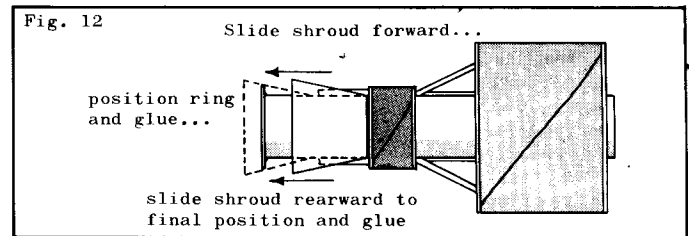

(13) Check the fit of the engine mount unit in the BT-70 tube. Sand the edges of the discs until the unit slides freely in the tube. Mark the inside of the BT-70 1/4" from the end. Smear glue around the inside of the tube to cover an area from 1/2" to 1-1/2" from the end. Slide the engine mount unit into the tube so the rear disc is even with the mark. Do not pause during this operation or the glue may set with the unit in the wrong place.

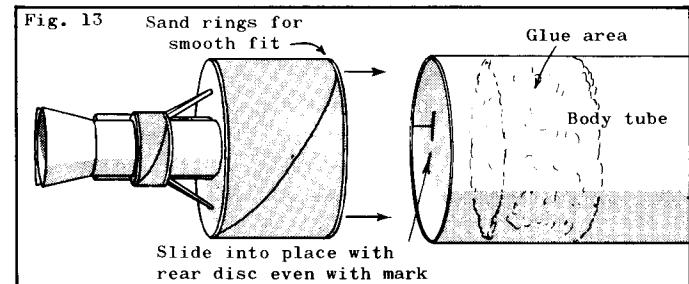

(14) Cut two slits in the front end of the BT-60K parachute tube, the one above the other, 1" and 1-1/4" from the front of the tube as shown. Press in the section between the slits and insert the shock cord. Tie a knot in one end of the cord and pull it up so the knot seats against the slits. Push the caved-in portion of the tube back out and smear glue over the cuts and the shock cord to anchor it in place.

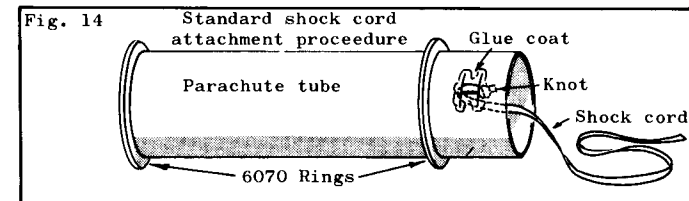

(15) Slide the 2060 ring on the stuffer tube 1/8" into the rear of the parachute tube. Apply a glue fillet to the joint between the ring and the larger tube. Set this assembly aside to dry.

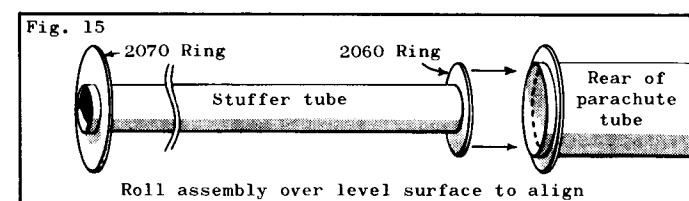

(16) Cut out the parachute on its edge lines as indicated on the plastic. Cut six 24" lengths of shroud line cord and attach one shroud line to each point of the parachute with a tape strip as shown in fig. 16. Tie the free ends of the lines together.

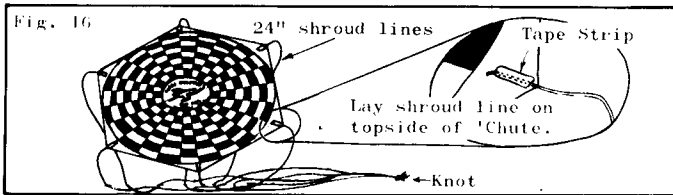

□ (17) Cut four 5/8" long pieces of 1/16" dowel. Glue these in place between the ends of the four struts from step 10 and the end of the body tube as shown in fig. 17A. Cut four 13/16" long pieces of dowel and glue them between the end of the body tube and the engine holder tubes as shown in fig. 17B. It may be necessary to sand the ends of the dowels slightly to make them fit.

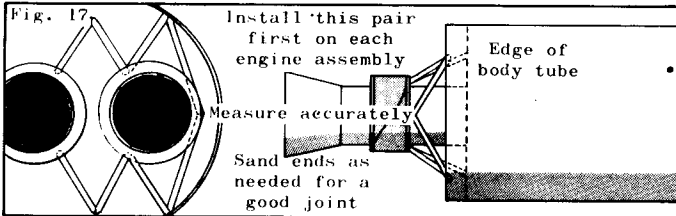

□ (18) The remaining tail detail is made by gluing two pieces of the BFS-40S balsa sheet together and carving to the shape shown in fig. 18A. Make two of these pieces, then glue them in place on the rear of the body as shown in fig. 18B.

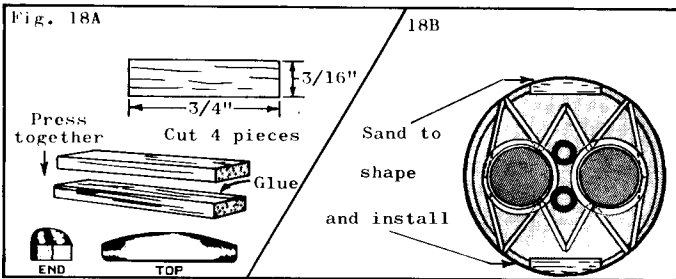

□ (19) Viewing the rocket from the rear, mark the tube 7/16" to the left (counterclockwise) of the point where a line drawn at 90° to the centerline of the engine tubes would meet the body. (See fig. 19A.) Using the "V" notch edge of a cabinet drawer, draw a straight line from this mark all the way up the body tube. Mark across the line at points 2-7/16", 5-11/16" and 14-1/16" from the rear of the tube. Cut one 2-3/4" piece and one 1-1/8" piece from the shorter length of launching lug. Glue these pieces to the line on the body in the positions shown. The rear ends of the lugs should be on the marks.

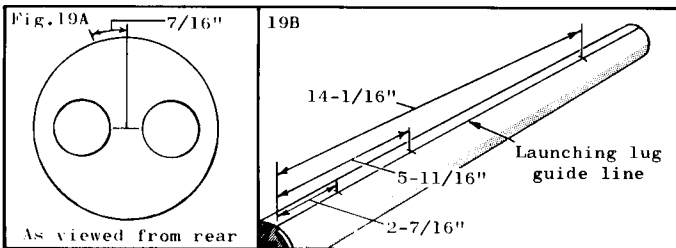

□ (20) Carve the hatch windows in the capsule to the shape shown in fig. 20. An extra sharp knife should be used. Carve the electronics package from the BFS-40S and glue it onto the capsule 90° to the right of the centerline between windows (as viewed from the front).

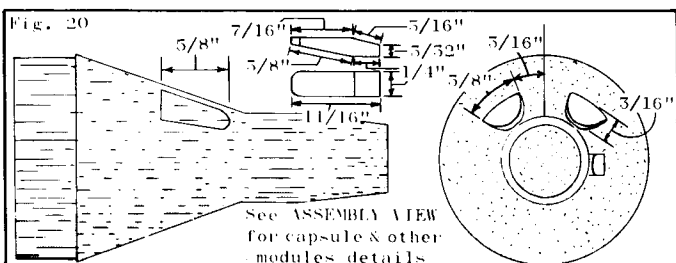

□ (21) Slide the stuffer-parachute tube assembly into the body. Slide the forward shroud onto the front of the model and position the inside tubes so the front of the parachute tube is even with the front of the shroud when the rear of the shroud is even with the front of the body tube. Remove the shroud and apply glue to the joint between the front ring on the parachute tube and the main body tube. Support the rocket vertically while this sets.

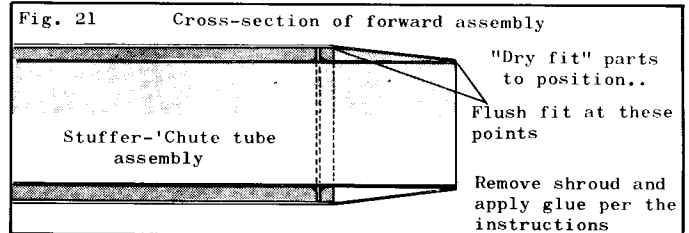

□ (22) Insert the screw eye into the rear of the capsule. Remove it, squirt glue into the hole and replace the screw eye.

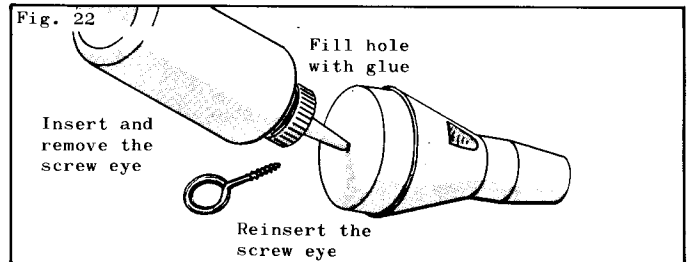

□ (23) Apply glue to the front edge of the body tube and to the outside of the parachute tube at the front. Slide the shroud into place, making sure that it is even with the body tube all the way around.

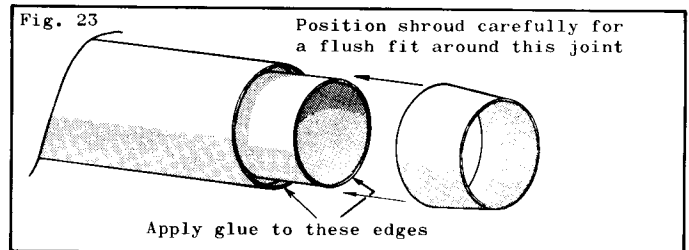

□ (24) Apply a coat of sanding sealer or Astroseal to the capsule. Let dry, then sand with extra fine sandpaper. Repeat this procedure until all the holes in the balsa are filled. Seal all other wooden parts on the model in the same way. Apply a white base coat to the entire rocket and capsule. When the paint has dried cut out the wrap-around pattern and transfer the outline of the different areas as directed on the pattern sheet. Apply the silver, let dry and follow with the black.

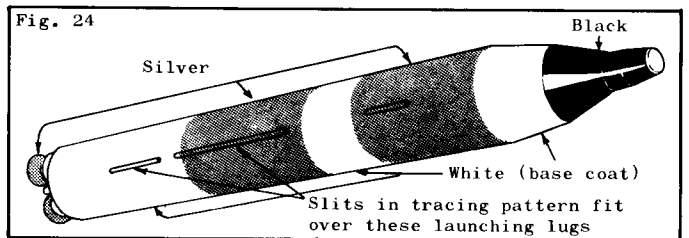

□ (25) After the paint has dried completely, wrap two layers of typing paper around the rear of the body tube. Cut the thin sheet of plastic fin material to a length of 7-1/2" and wrap it around the paper. Apply clear butyrate dope to the overlap joint and press the ends together to glue them. (Tape may be used to hold the joint while it dries.)

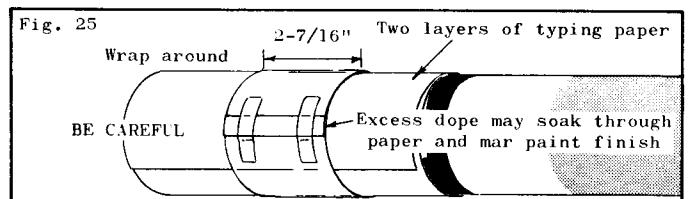

(26) Cut out the fin pattern. Position it on one of the sheets of plastic and trace around it with a ball point pen. Trace out all four fins in this manner. The fins may then be cut from the sheets either with an extra sharp pair of scissors or by scoring along the line with a sharp knife and bending on the line to break the plastic. (It is best to experiment on an unused corner of the plastic before cutting out the fins themselves.)

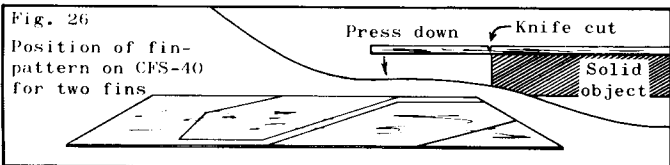

(27) Cut out the fin spacing guide. Slide the ring off of the body, remove the paper and wrap the spacing guide around the rear of the body. Slide the ring back on over the spacing guide. Apply a liberal layer of clear butyrate dope to the root edge of a fin and press it against the ring over one of the lines on the spacing guide. Hold it in place until the dope sets, then attach the other fins in the same way. After all fins have dried, apply a fillet of dope to the fin-ring joints.

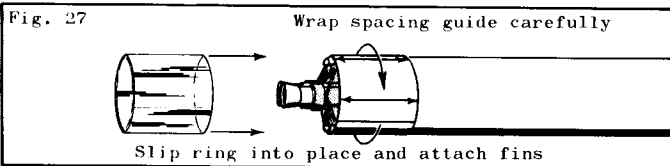

(28) Tie the end of the shock cord to the screw eye in the capsule and secure it with the remaining tape strip as shown. Tie the ends of the shroud lines to the screw eye.

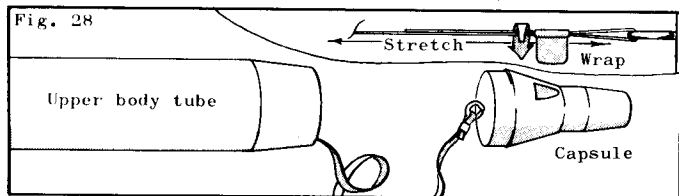

LAUNCHING THE TITAN

The recommended engine types for the Gemini-Titan are the A8-3, B6-4, and C6-5. When flying make sure that both engines are of the same type. The electrical igniters for the engines are hooked together in parallel (not series). The power supply for the launcher must be strong enough to ignite both engines immediately and simultaneously. If one engine fails to ignite the model will not reach sufficient flying speed and will crash. A 24 volt Electro-Launch in good condition or a 12 volt car battery with no more than 18 feet of #18-2 lead wire will do the job. Make sure the electrical system is in perfect operating condition before attempting to launch your model.

Launch the Gemini-Titan from a 1/8" diameter rod at least 36" long. A 54" rod will give better control of the flight path. The fin unit should be anchored securely to the body--if it does not fit tightly, use cellophane or clear plastic tape to secure it in place.

FIN CARE

When the rocket is on display the fin unit may be removed. However, the fin unit should be stored on a tube of the same diameter as the rocket body to keep it from distorting. Such a tube may be formed by wrapping an old mailing tube with paper to bring it up to the desired size. If the ring portion of the unit becomes too tight to fit onto the body tube, it is possible to slit it as shown and secure it on the model by taping across the slit with cellophane tape.

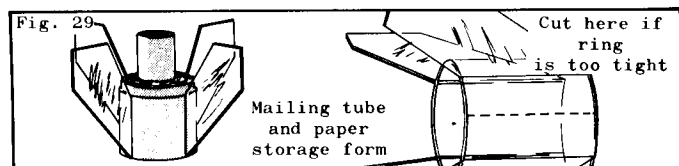

COUNTDOWN CHECKLIST

-15- Pack flameproof recovery wadding into the 'chute tube from the top. The wadding should fill the tube for a distance of about 2 to 2-1/2 inches and seat against the sides of the tube (8 to 10 squares of RP-1A are recommended). Hold the parachute between two fingers at its center and pass the other hand down it to form a "spike" shape. Fold this spike in two or three sections as shown in the illustration. Push the folded parachute down into the tube on top of the wadding and pack the shroud lines and shock cord in on top of the parachute. Slide the capsule into place.

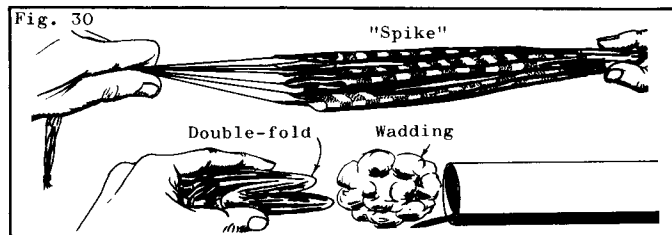

-14- Select the engines. A.8-3 engines are best for the first flights. Install electrical igniters in the engines as directed in the instructions which came with the engine.

-13- Wrap the engines with masking tape until they make tight fits in the engine holder tubes. This fit must be tight so the engines will not blow out when the ejection charges are activated. Align the engines so the leads on their igniters are at a 90° angle to the line between the engine tubes and press them forward into the tubes until their front ends rest against the engine blocks.

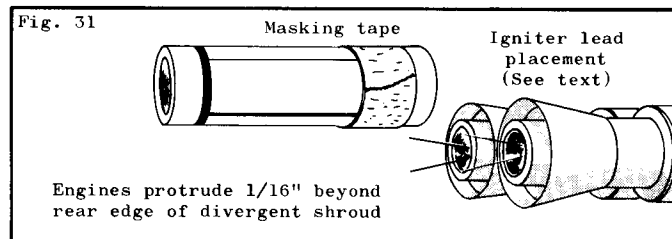

-12- Twist the ends of the igniter leads together as shown. Be sure they make good contact with each other, but do not twist so much that the igniters are pulled loose.

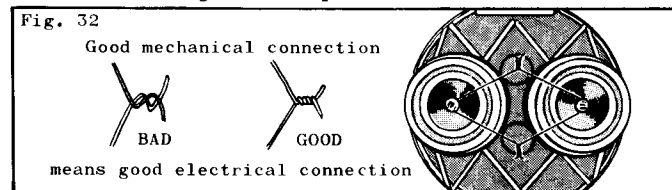

-11- Check the power supply by connecting two 1-1/2' pieces of #30 or #32 nichrome wire (or two standard igniters) between the micro-clips and pressing the launch switch. The igniters should get red hot immediately. If they do not, make whatever adjustments are necessary to obtain proper operation.

-10- Remove the safety interlock or key from the launch control panel. (If a simple spring switch is used, install the protector on the switch to separate the contacts.) Carry the key or interlock on the person of the launch control officer.

-9- Place the rocket on the launcher. Check to be sure the panel is disarmed. Clean the micro-clips and attach them to the igniters at the points where they are twisted together.

-8- Clear the launch area, alert the recovery crew and trackers.

-7- Check for low flying aircraft and unauthorized persons in the recovery area.

-6- Arm the launch panel.

-5- -4- -3- -2- -1- LAUNCH!

SP-21

For best results use a straightedge for guide in cutting plastic.

FIN PATTERN
(PFS-40)

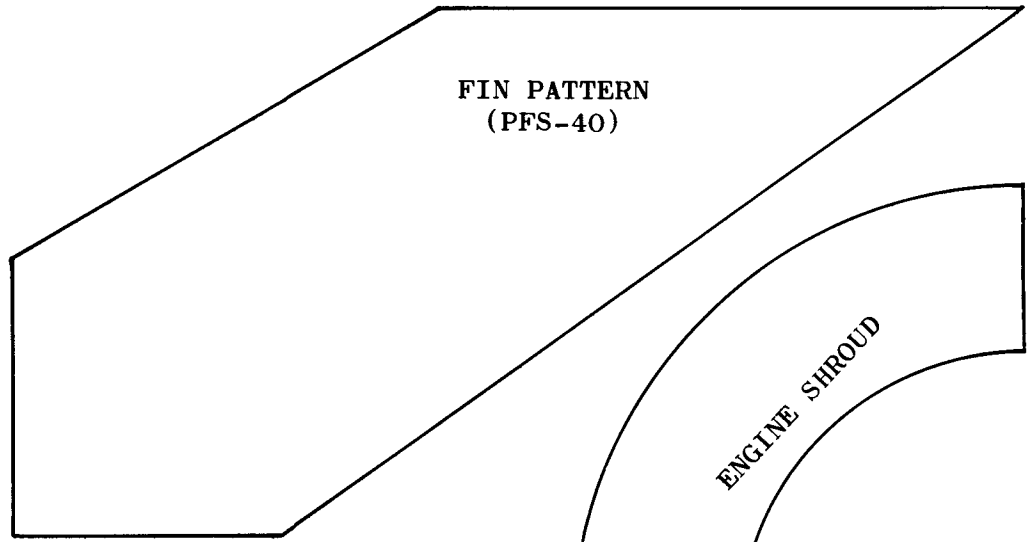

ENGINE SHROUD

FORM SHROUDS WITH
PRINTING TO THE
INSIDE

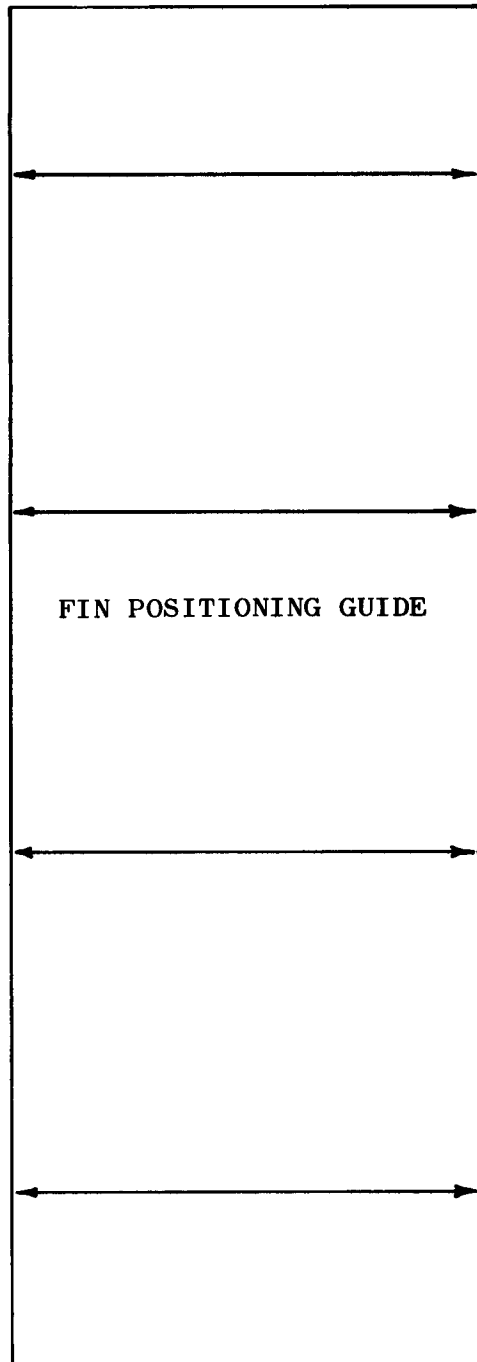

FIN POSITIONING GUIDE

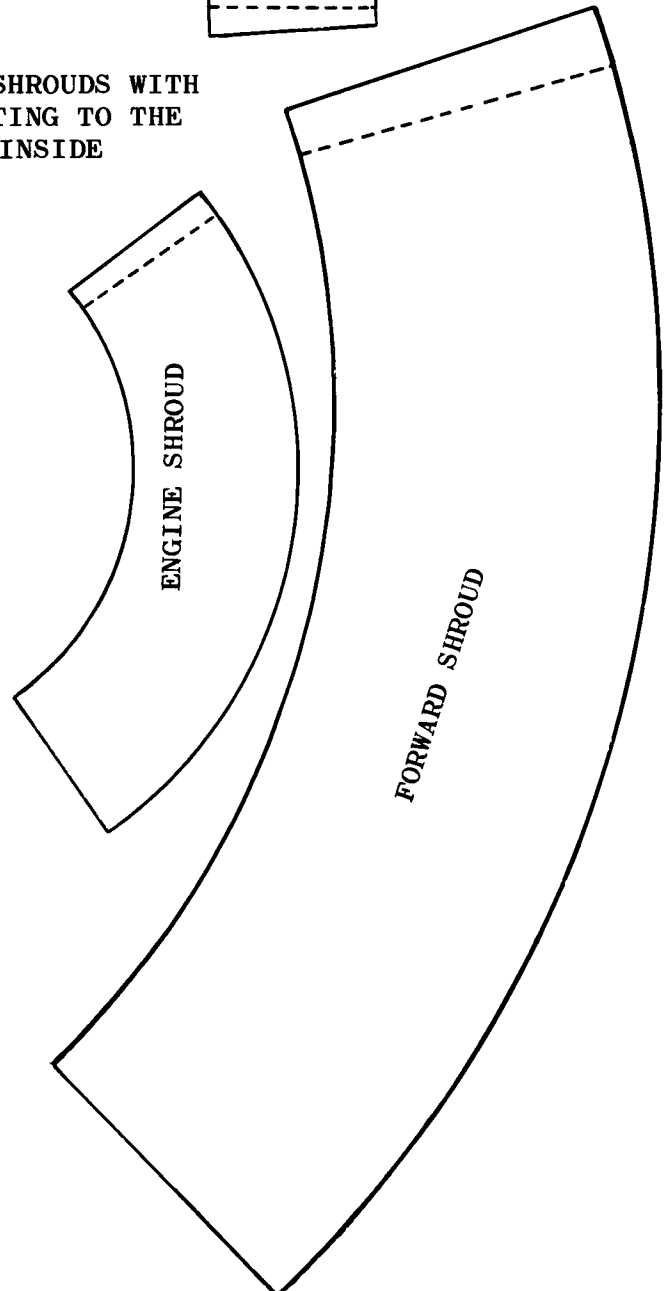

ENGINE SHROUD

FORWARD SHROUD

CAPSULE DETAIL

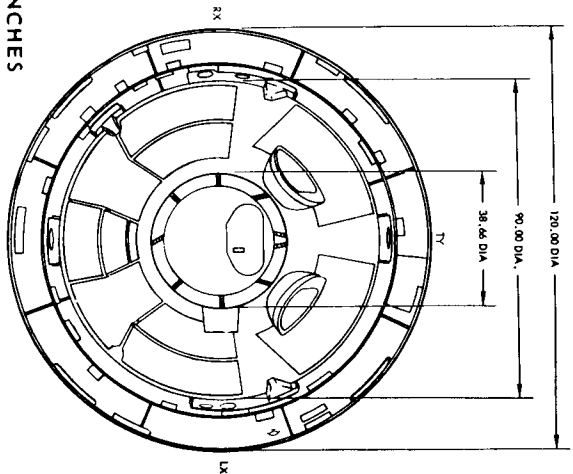

DIMENSIONS IN INCHES

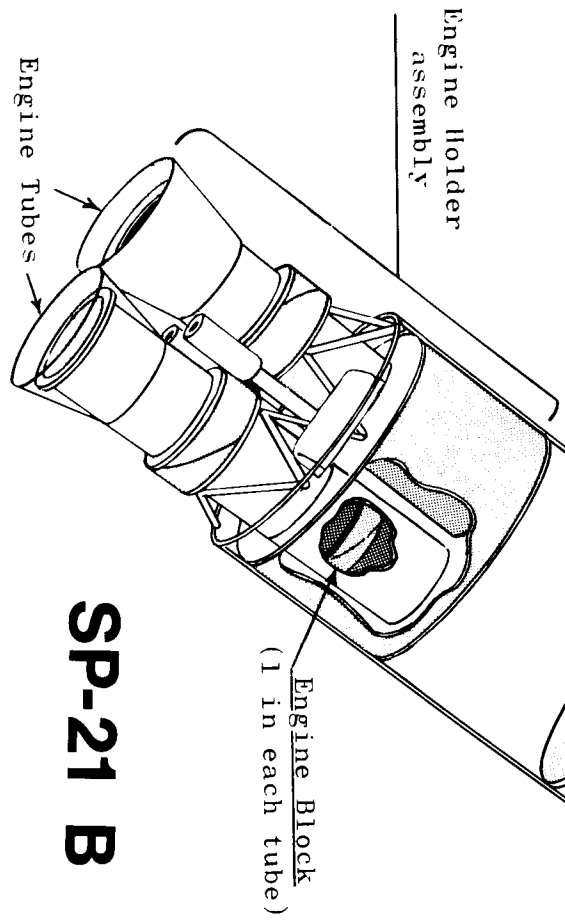
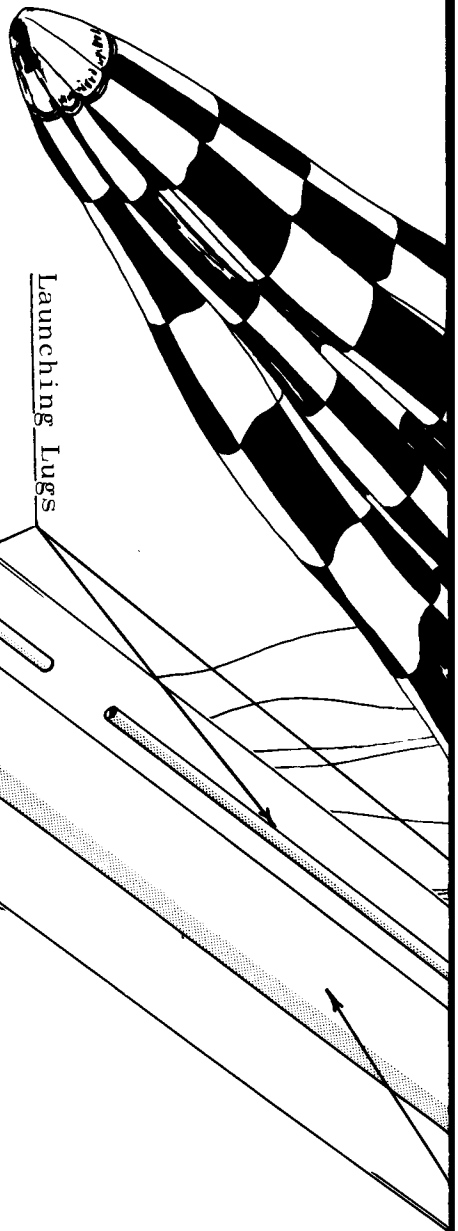
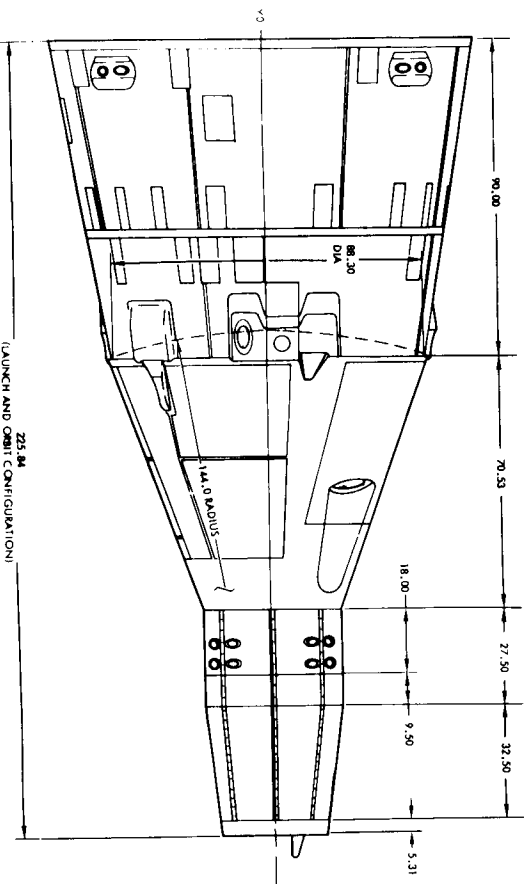

SP-21 B



A SUBSIDIARY OF DAMON
ESTES INDUSTRIES
PENROSE, COLO. 81240

Scale dimensions and color scheme for the Titan II were provided by the Martin Company, Denver, Colorado, prime contractor for the vehicle. Capsule details and dimensions were supplied by McDonnell Aircraft Corp., Saint Louis, Missouri.

GEMINI-TITAN

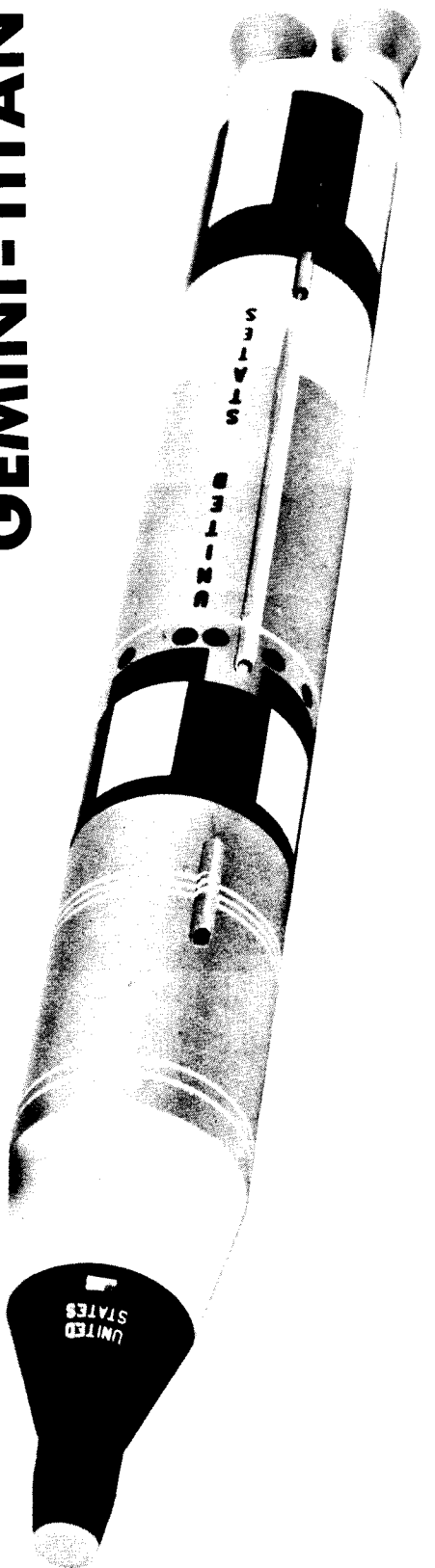

ASSEMBLY VIEW

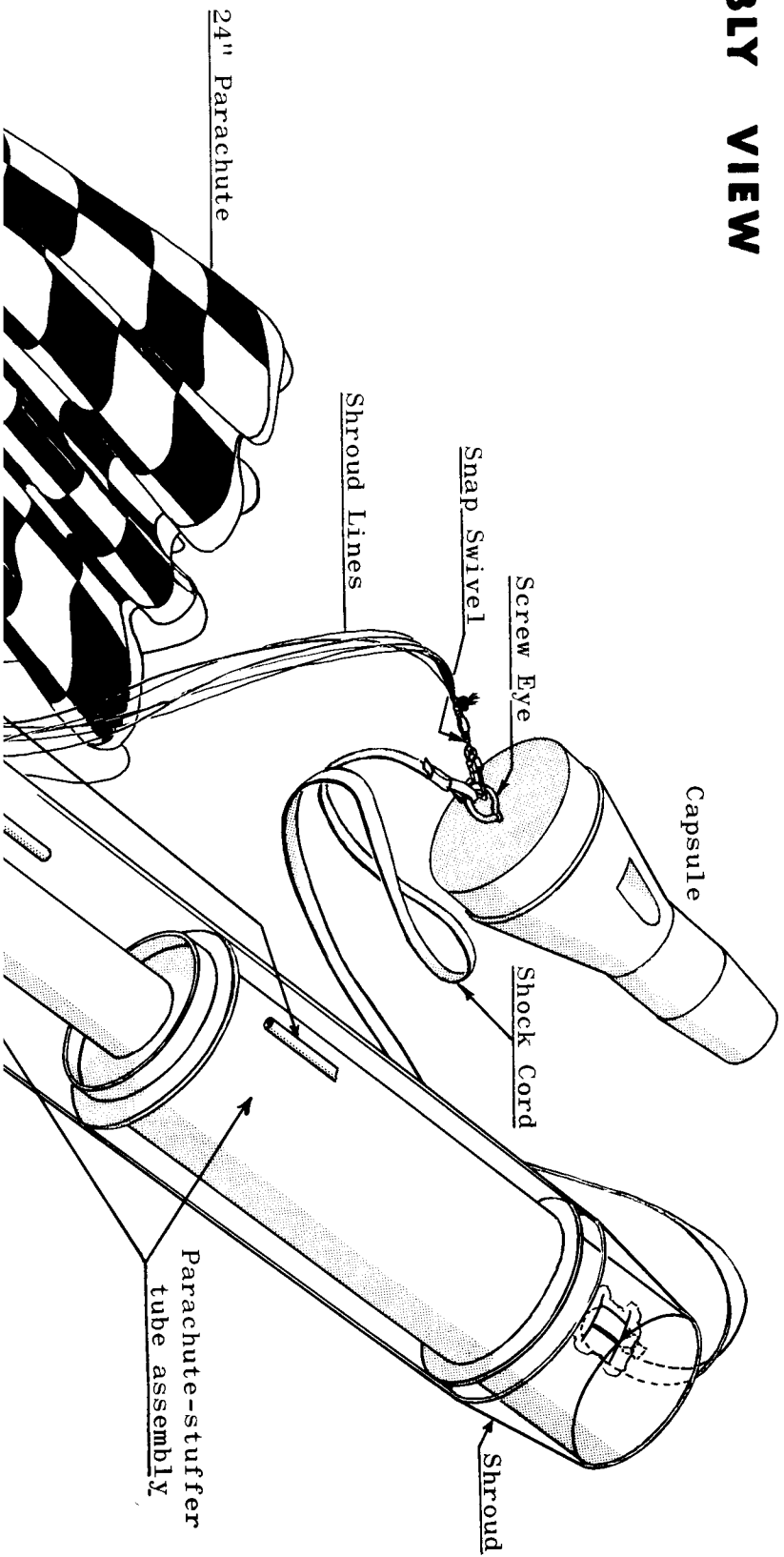

GEMINI / TITAN II COLOR SCHEMATIC

READ CAREFULLY BEFORE CUTTING OUT LOWER BODY WRAP-ON TRACING PATTERN

Cut out the tracing pattern. Cut out the two slots. Cover the backside of the pattern with a soft lead pencil wherever lines or black areas of detail is to be traced. Saturate a Q-Tip or other swab with lighter fluid and wipe quickly over all the pencil marks. This "sets" the graphite and removes loose particles that may otherwise smudge the base finish. Wrap the tracing pattern around the lower section of the body tube with slots positioned over the launching lugs. If the bottom edges of the pattern and body tube are not flush, correct the position of the launching lugs to accomplish this fit.

Tape the side edges of the pattern together matching all lines. Use a straightedge where possible, in tracing over all details. Remove the tracing pattern and be sure all details have been transferred to the body tube. Black ENAMEL paint is recommended as it is less prone to leaving brush marks.

SILVER is base color for remainder of body tube above this line

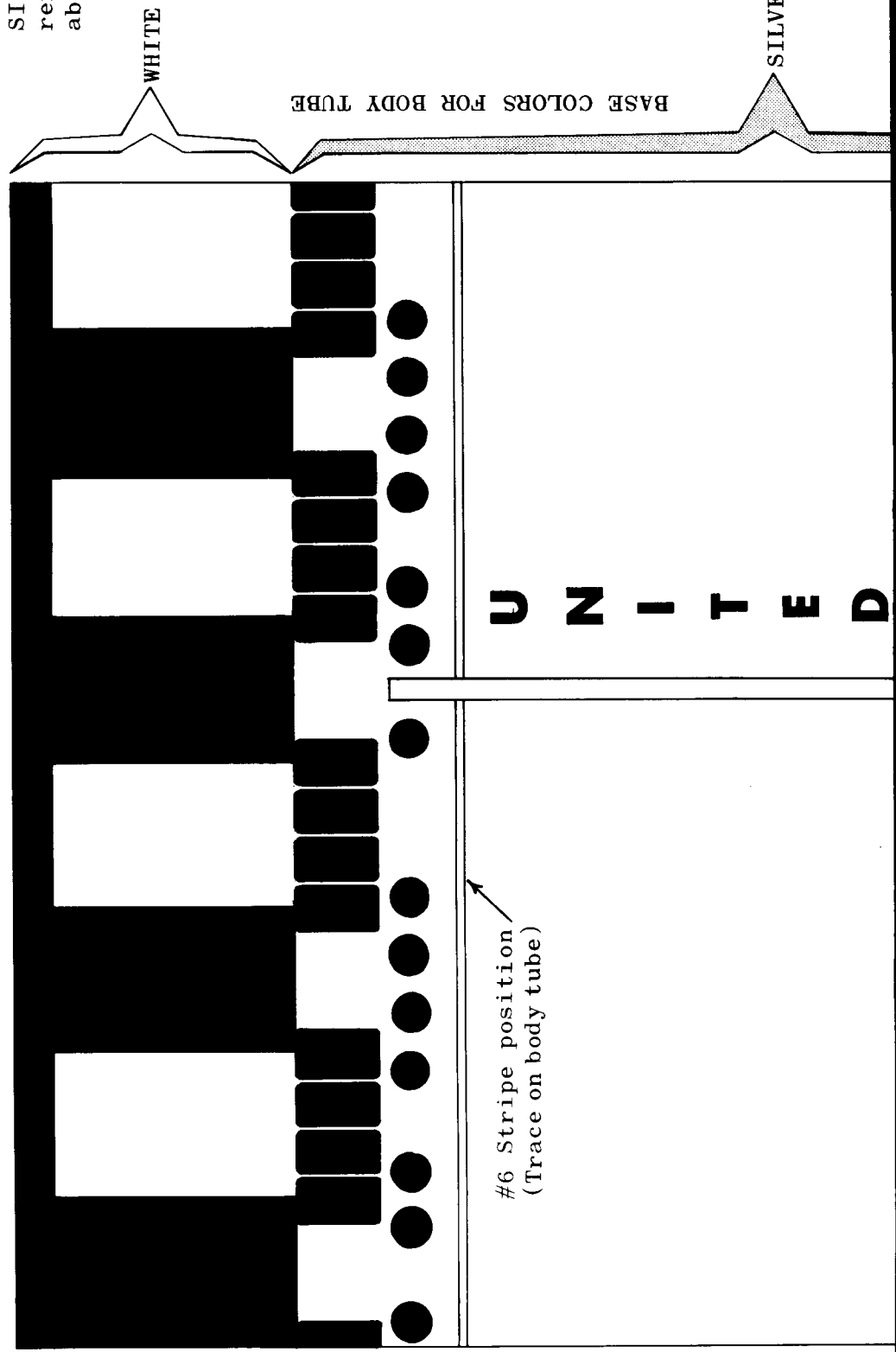

UPPER BODY AND CAPSULE DETAIL

WHITE TOP. Bring color over edge to depth of 1/16"

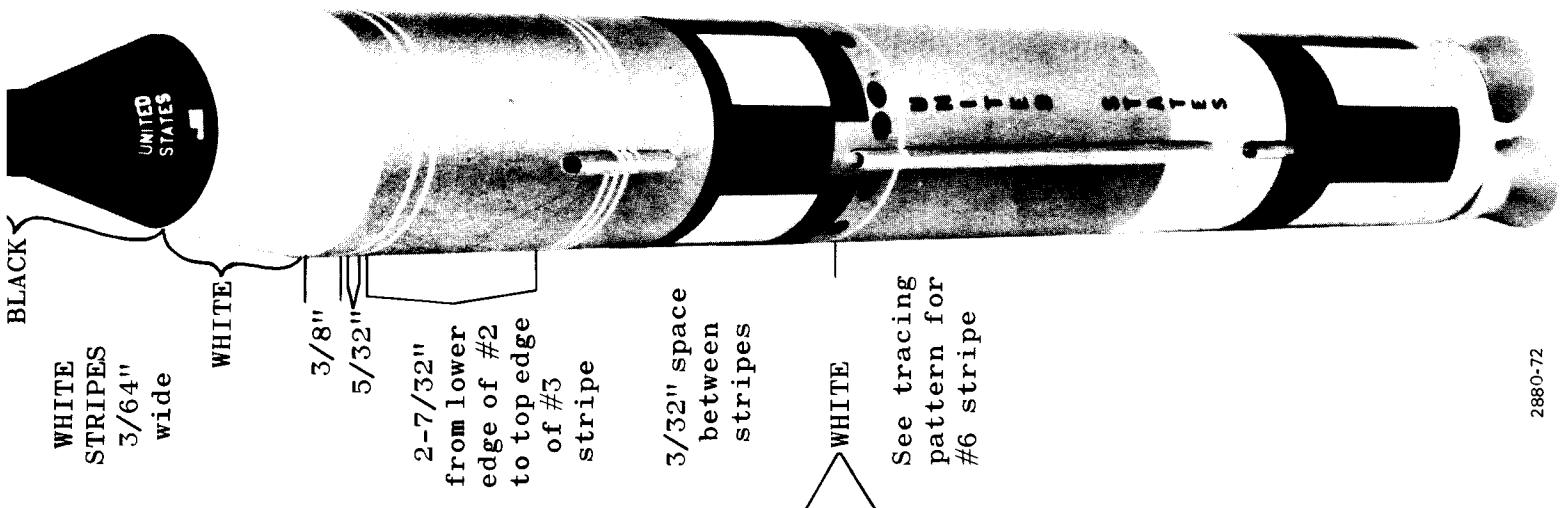

BLACK

WHITE STRIPES
3/64"
wide

WHITE

3/8"

5/32"

2-7/32"
from lower
edge of #2
to top edge
of #3
stripe

3/32" space
between
stripes

WHITE

See tracing
pattern for
#6 stripe

S T A T E S

Black areas on this pattern
indicate black paint areas
to appear on body tube

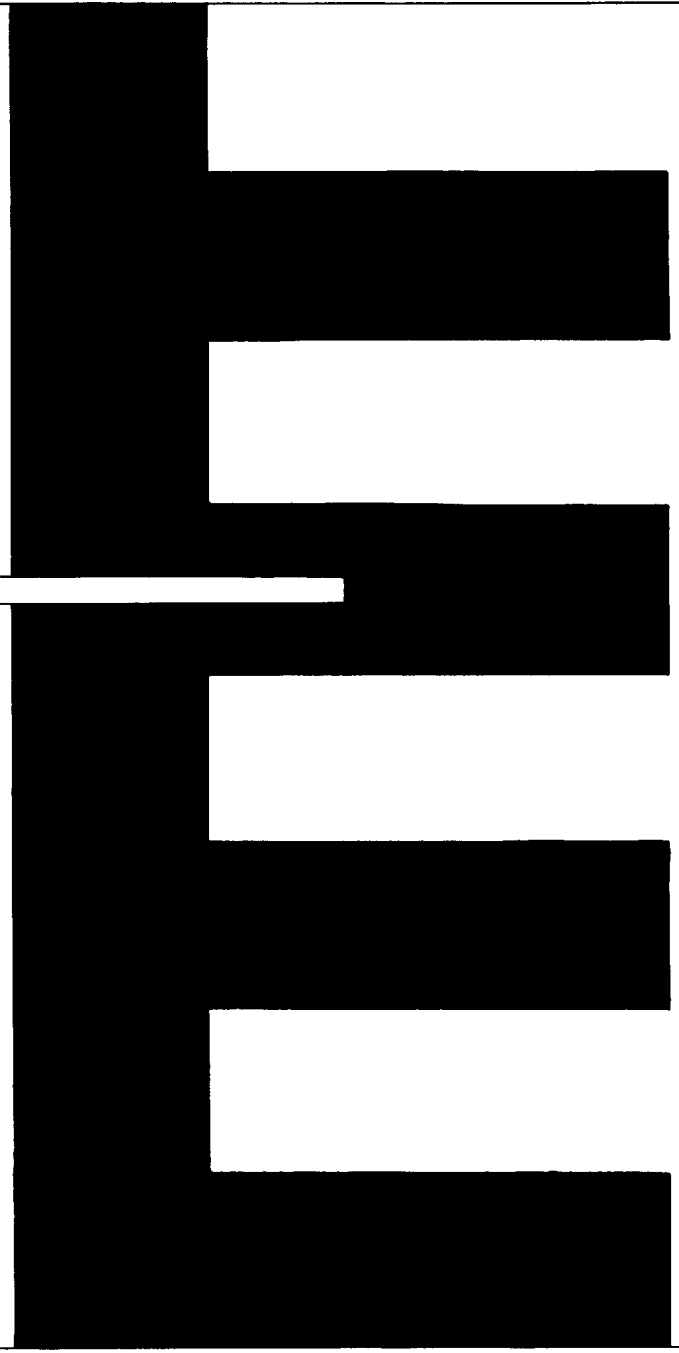

This edge should be flush with
rear edge of body tube

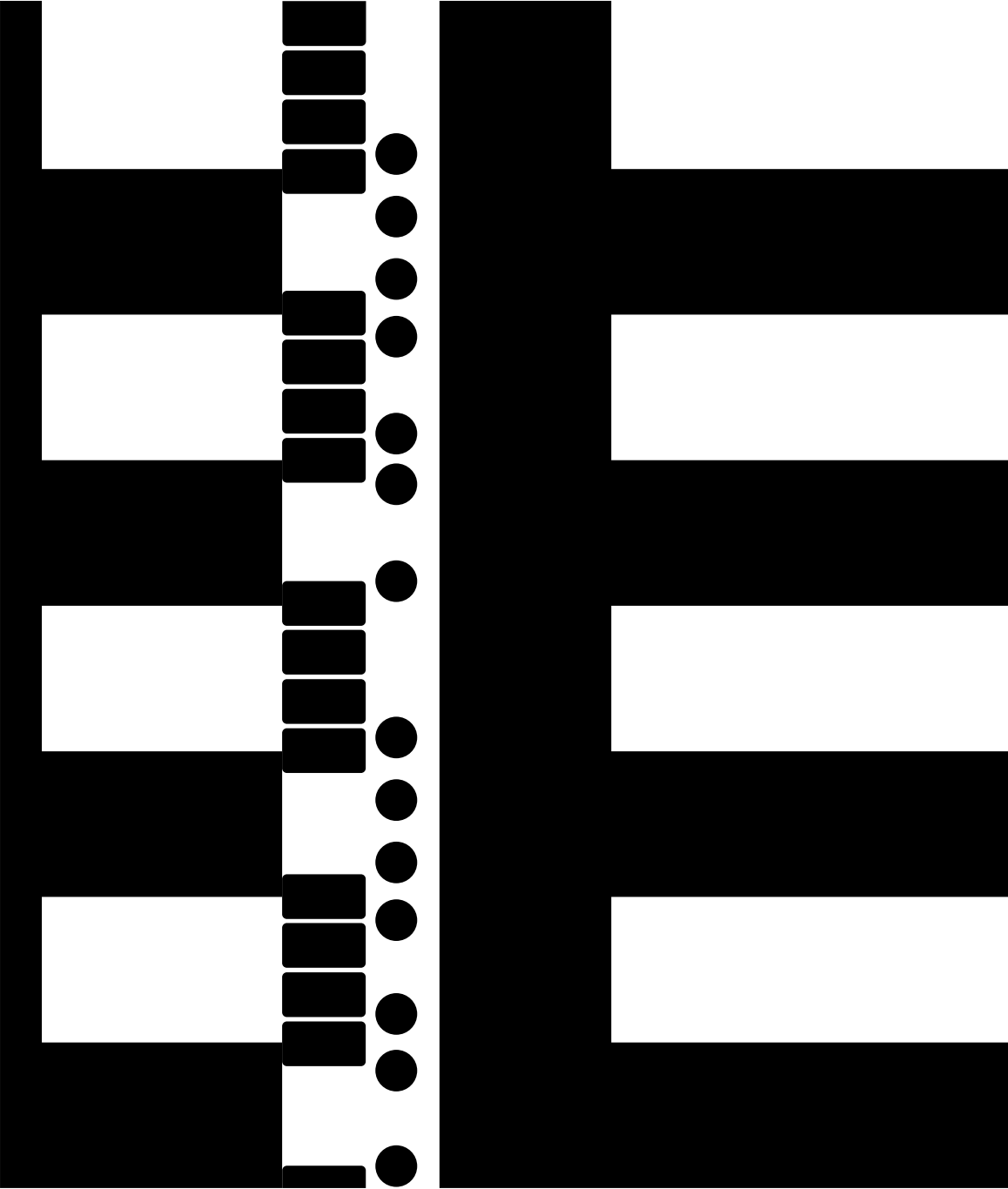

**U U
N N
I I
T T
E E
D D

S S
T T
A A
T T
E E
S S**